

FIL ROUGE  
5<sup>Th</sup> ELEMENT OXI UP  
SCHERMI CONTENITORI  
UNIVERSALI PIEGO  
CHIUDO SEGUO JERA  
ENOSI E.O.S. IULIO  
ELITE DELTA **I-MEET**  
PAUSA CONVIVIO  
FUNGO SEGNO ICARO  
NICE POINT

LAS<sup>®</sup>

# I-Meet

Nikolas Chachamis - CSR Las Mobili



## La collezione si caratterizza per:

**01/** Gambe in acciaio cromato lucido o verniciate nero opaco. **02/** Postazione relatore a cattedra singola e doppia. **03/** Leggio. **04/** Contromobile con basamento metallico. **05/** Modulo top access elettrificato e non con apertura basculante. **06/** Wire manager sottopiano. **07/** 4 finiture di legni e 2 tinte unite per i piani. **08/** 1 finitura in vetro.

## This collection is characterised by:

**01/** Polished chrome-finished steel legs or matt black painted legs. **02/** Speakers' place with single or double desk. **03/** Podium. **04/** Matching furniture with metal base. **05/** Wired and non-wired top access module with tilting opening. **06/** Under-the-top wire manager. **07/** 4 wood finishes and 2 plain colours for the worktops. **08/** 1 glass finish.

## La collection est caractérisée par :

**01/** Pieds en acier chromés polis ou peints en noir mat. **02/** Poste de l'orateur à table single ou double. **03/** Pupitre. **04/** Contre-meuble avec base en métal. **05/** Module top-access électrifié ou non électrifié avec ouverture basculante. **06/** Système de gestion des câbles sous le plateau. **07/** 4 finitions en bois et 2 couleurs pleins pour les plateaux. **08/** 1 finition en verre.







cod. 12



cod. NR 03

cod. 56



↑  
Tavolo riunioni  
in formato  
quadrato con top  
access centrale.

Square meeting  
table with  
central top  
access.

Table de réunion  
carré avec top  
access central.

**Tavoli riunioni in vari formati, variamente aggregabili fino alle grandi composizioni. La riduzione degli appoggi e la sezione snella delle gambe conferiscono grande leggerezza e stabilità ad ogni composizione, permettendo un perfetto utilizzo su ogni lato.**

Meeting tables in different formats that can be combined in a number of ways up to large compositions. The reduction of supporting elements and the slender legs add lightness and stability to each composition, allowing perfect use on all sides.

Tables de réunion dans formats différents, qui peuvent être combinées pour obtenir de grandes compositions. La réduction des appuis et la section élancée des pieds donne une grande légèreté et stabilité aux compositions, pour une utilisation parfaite sur tous les côtés.



cod. 30

→  
L'angolo è  
caratterizzato  
dallo smusso che  
segue la posizione  
della gamba.  
Corners are  
characterised  
by the bevelling  
that mirrors the  
leg position.  
Le coin est  
caractérisé par  
le biseau qui suit  
la position de  
la jambe.



**Nelle grandi composizioni è assicurato un ottimale cablaggio in ogni posizione, grazie a top access lineari e ampi Wire Manager per le salite.**

In large compositions, optimal wiring is available in all positions, thanks to linear top access openings and large Wire Managers for upward wiring.

Dans les grandes compositions, le câblage optimal est assuré dans n'importe quelle position, grâce au top access linéaire et aux amples systèmes Wire Managers pour les montées des câbles.

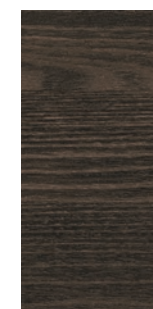

cod. 52







→  
 Il cablaggio è facilmente accessibile e perfettamente nascosto.  
 Wiring is easily accessible and completely hidden.  
 Le câblage est facilement accessible et parfaitement caché.



cod.NR 03 cod.12

**In ambienti conferenza o formazione la postazione dei relatori assume un valore comunicativo e tecnico ineccepibile. Il livello estetico è adeguato alla qualità dell'ambiente, le dotazioni tecnologiche soddisfano le funzioni specifiche di una relazione in presenza o online.**

Dans les salles de conférence ou de formation, la position des intervenants acquiert une valeur communicative et technique impeccable. Le niveau esthétique est conforme à la qualité de l'environnement, les équipements technologiques répondent aux fonctions spécifiques des relation en face à face ou en ligne.

In conference or training environments, the speakers' seat features an impeccable communicative and technical value. The aesthetic level is up to the quality of the environment, with technological equipment that meet specific functions of both face-to-face and online relationships.









←  
L'angolo smussato  
mantiene lo stesso  
allineamento della  
gamba.  
Bevelled corners  
maintain the  
alignment with the  
legs.  
Le coin arrondi  
maintient le même  
alignement du pied.

**I piani di lavoro in cristallo  
retro laccato conferiscono  
grande eleganza al tavolo  
riunioni e si pongono  
in contrapposizione col  
modulo tecnologico  
centrale in legno.  
Un ulteriore livello di pregio  
di materiali ed abbinamenti  
per un meeting moderno ed  
elegante.**

Back-lacquered glass  
worktops give great  
elegance to the meeting  
table and create contrast  
with the wood of the  
central technical module.  
An additional level of  
quality in materials and  
combinations, for modern  
and elegant meetings.

→  
Tavolo riunioni  
quadrato con  
modulo tecnico  
centrale.  
Square meeting  
table with  
technical  
central module.  
Table de réunion  
carré avec  
module technique  
central.



cod. 10

Les plans de travail en  
verre rétro-laqué donnent  
une grande élégance à  
la table de réunion et  
contrastent avec le module  
technologique central en  
bois. Un ultérieur niveau de  
prestige dans les matériels  
et les combinaisons pour  
des rencontres modernes et  
élégants.



**Tavoli riunione**  
Meeting tables | Tables de réunion

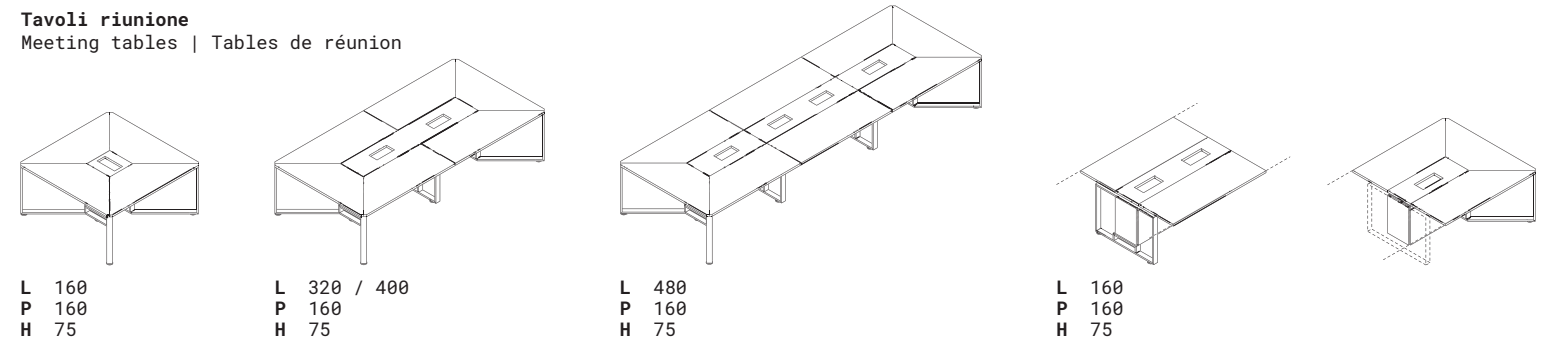

L 160  
P 160  
H 75

L 320 / 400  
P 160  
H 75

L 480  
P 160  
H 75

L 160  
P 160  
H 75

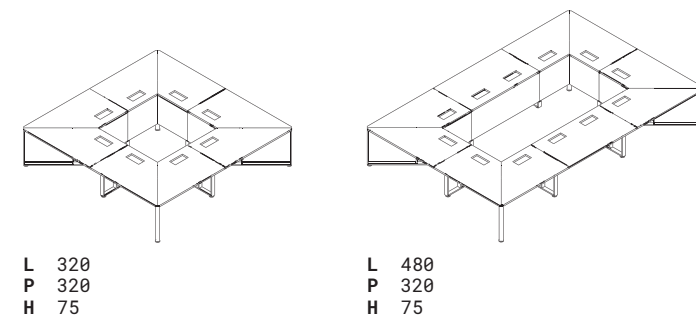

L 320  
P 320  
H 75

L 480  
P 320  
H 75

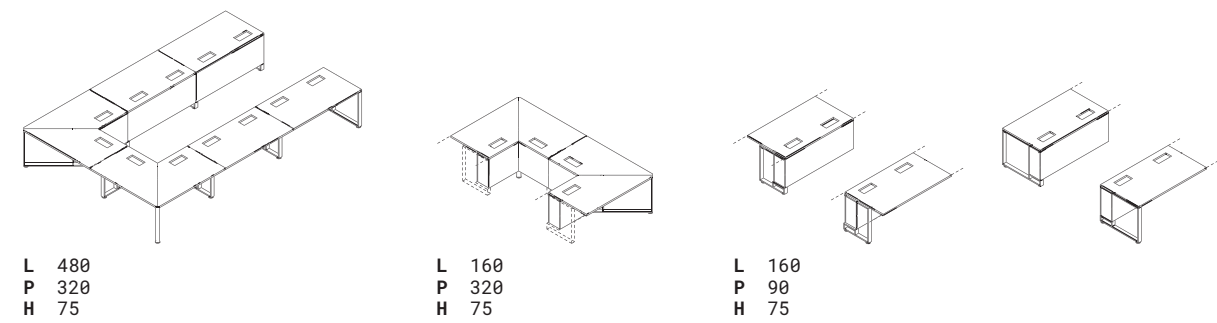

L 480  
P 320  
H 75

L 160  
P 320  
H 75

L 160  
P 90  
H 75

**Complementi di arredo**  
Accessories | Meubles de rangements

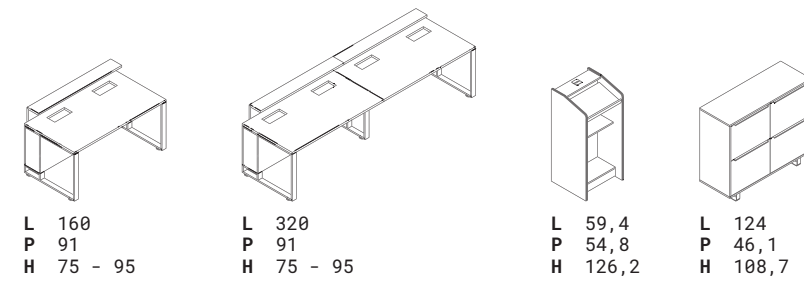

L 160  
P 91  
H 75 - 95

L 320  
P 91  
H 75 - 95

L 59,4  
P 54,8  
H 126,2

L 124  
P 46,1  
H 108,7